

CORI-FLOW®

액체 및 가스용 초정밀 질량 유량계/컨트롤러 Liquids and Gases



개요

Bronkhorst Cori-Tech는 coriolis의 측정 기술을 바탕으로 정밀하고 콤팩트한 질량 유량계/제어기(가스 및 액체)를 제작합니다. 이 제품은 장비회사, 파일럿플랜트 및 연구분야 사용에 적합하도록 고객 사양에 맞게 제작되었으며 산업분야 및 위험 지역에서의 적용이 가능한 제품도 제공하고 있습니다.

CORI-FLOW® series direct mass flow meters and

CORI-FLOW® 질량 유량계/컨트롤러 저유량 측정 및 제어에 우수한 Bronkhorst사는 3가지 등급의 높은 고정도의 질량 유량 측정 기기인 CORI-FLOW series를 제공합니다.

(3가지의 클래스: $\pm 0.2\%$, $\pm 0.5\%$, $\pm 0.1\%$ of RD)

CORI-FLOW®는 온도, 열전도율, 밀도, 온도, 압력의 변화에도 뛰어난 측정정도에 영향을 끼치지 않으며 여타의 제품과는 다른 높은 성능을 보증하는 특허를 취득한 코리올리 타입 질량 유량 센서를 사용하고 있습니다. 이 기기는 질량 유량계로서 컨트롤밸브 및 펌프와 조합하여 제곱 컨트롤러로도 제공합니다. 표준으로 아날로그(0~5Vdc/4-20mA)와 RS232출력을 더하여 옵션으로 각종 통신 프로토콜(DeviceNet™ / PROFIBUS-DP® / Modbus-RTU 또는 FLOW-BUS)용 인터페이스 보드를 추가 하는것으로 간단하게 통신이 가능하게 됩니다.

200g/h~600kg/h(full scale)의 범위로 각각의 유량범위에 따라 4종류의 모델이 있습니다. 또한 각 모델은 다양한 범위 설정기능을 가지고 있습니다. 유량계 및 컨트롤러는 IP65 housing으로 되어 있으며 ATEX인증 ZONE 2의 위험장소 사양도 준비되어 있습니다.

Fields of application

CORI-FLOW®기기는 반도체, 연료전지, 바이오(발효등), 의약, 석유화학, 과학, 식품등의 분야에서 프로세스 유체의 측정/제어에 이용되고 있습니다. 브로셔에서 더 많은 적용분야를 참조하십시오.

일반적인 특징

- > 직접 질량 계측
- > 유체의 특성에 영향을 받지 않음
- > 컨트롤 밸브와 펌프의 통합 PID제어 기능내장
- > 고속응답
- > 고 정확성 및 탁월한 반복성
- > 컴팩트한 사이즈, IP65 housing
- > ATEX Cat.3, Zone 2
- > 옵션 : 2방향성 계측 가능

디지털 특징

- > RS232 interface
- > DeviceNet, Profibus-DP, Modbus-RTU, FLOW-BUS slave
- > 그외 fieldbus (on request)
- > 알람, 적산 기능

CORI-FLOW[®] for Liquids and Gases

측정 원리(Measuring principle)

CORI-FLOW[®]기기는 2개의 평행한 튜브 고리로 구성된 진동 시스템의 방식으로 튜브내 유량이 흐를때 코리올리의 힘에 의해 두 고리 사이의 뒤틀림 각이 발생합니다. 이것을 센서가 감지하여 기기내 pc보드로 보내어져 유량값을 측정합니다.

이 출력값의 신호는 실 질량 유량율에 비례합니다.

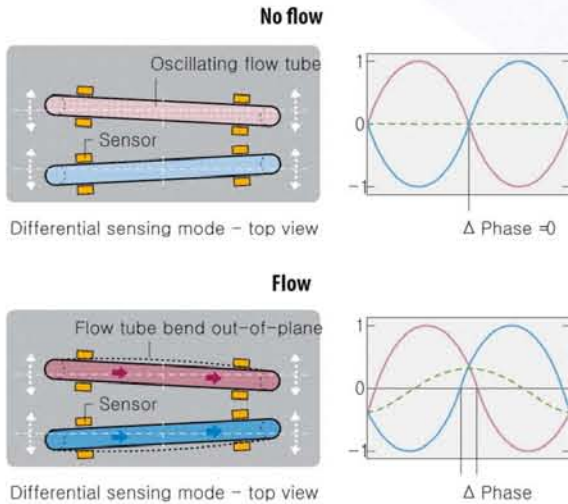

기술 사양

Performance flow sensor	
Accuracy	Liquid : 0,2% of rate + zero stability, range 20:1 Gas : 0,5% of rate + zero stability, range 50:1
Smallest Full Scale flow rates (values in kg/h)	
	M53 M54 M55
Max. flow FS	10 100 600
Min. flow FS Liquids	0,5 5 20
Min. flow FS Gases	1 10 50
Recommended min. flow	0,05 0,2 0,5
Zero stability	< 0,010 < 0,050 < 0,100
Repeatability	: 0,1% of rate (based on digital output)
Mounting position	: preferred mounting position on liquid service upside down
Operating limits flow controller	
Control range	: 2...100% (with elastomeric seat)
Auto shut off	: valve closes when setpoint drops below 1,6%
Liquids and Gases	: any clean, homogeneous liquid or gas compatible with AISI 316 (or Hastelloy-C22 as an option)
Differential pressure mass flow controller	: recommended Δ P across control valve at least 50% of total Δ P for liquids and gases.
Settling time	: approx. 0,5 s

Mechanical	
Process connections	: std. 1/4" face seal male, or 1/8", 1/4" or 6 mm OD compression type; other on request
Material of construction (wetted parts)	: stainless steel AISI 316 or equivalent; option for M52 / M53 / M54: Hastelloy-C22
Weight	: meter: approx. 3,1 kg meter + integral valve: 4,4 kg (max.)
Ingress protection	: IP 65 (weatherproof) for meter; for controller on request
Leak integrity	: < 2×10^{-9} mbar l.s ⁻¹ He
Pressure test	: 1,5 times max. stated operating pressure prevailing at customer
Max. operating pressure	: 100 bar
Temperature range (ambient + fluid)	: 0...70°C for standard version, 0...120°C with remote electronics, 130°C \leq 1 hour allowed for CIP
Electrical	
Power supply	: +15...24 Vdc \pm 10%; (DeviceNet™ +24 Vdc only)
Consumption electronics	: approx. 80 mA at 15 Vdc
Consumption valve (if present)	: 250 mA (max) at 15 Vdc
Output signal	analog : 0...5 (10) Vdc; 2 kOhm min. load 0 (4)...20 mA (sourcing); 375 Ohm max. load digital : Profibus-DP [®] , DeviceNet™, FLOW-BUS, RS232, Modbus, LonWorks
Command signal	analog : 0...5 (10) Vdc; 424 kOhm load 0 (4)...20 mA (sinking); 250 Ohm load digital : Profibus-DP [®] , DeviceNet™, FLOW-BUS, RS232, Modbus, LonWorks
Electr. connection	: male, 8-pin Amphenol for power, analog I/O and RS232 option : standard M12 connector for Profibus-DP [®] (female) or DeviceNet™/FLOW-BUS (male)/Modbus (male)
CE approved design	



CORI-FLOW[®] Mass Flow Meter with pressure actuated control valve

CORI-FLOW[®] mass flow meter/controller

Flow capacity liquid

Basic model	DN (mm)	Nominal Flow*	Capacities (kg/h)													
			0,5	1,0	2,0	5,0	10	20	50	100	200	500	600			
M53	1	5 kg/h	•	•	•	n	•	•	•	•	•	•	•	•	•	•
M54	2	50 kg/h	•	•	•	•	•	•	n	•	•	•	•	•	•	•
M55	4	500 kg/h	•	•	•	•	•	•	•	•	•	•	n	•	•	•

* Nominal flow: mass flow rate of liquid at a pressure drop of approx. 1 bar and based on reference conditions of water at approx. 20°C.
 ** Lowest recommended value for optimal performance is 20 g/h.

Dimensions (mm)

M50-Series Mass Flow Meter

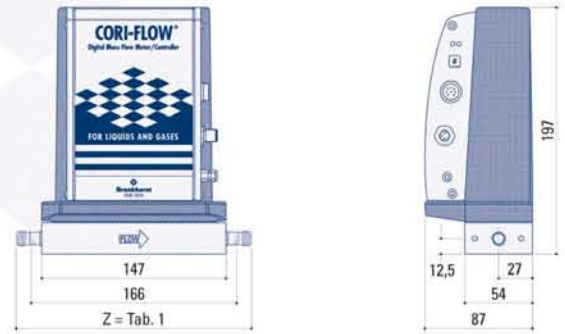

Pressure drop liquid (H₂O)

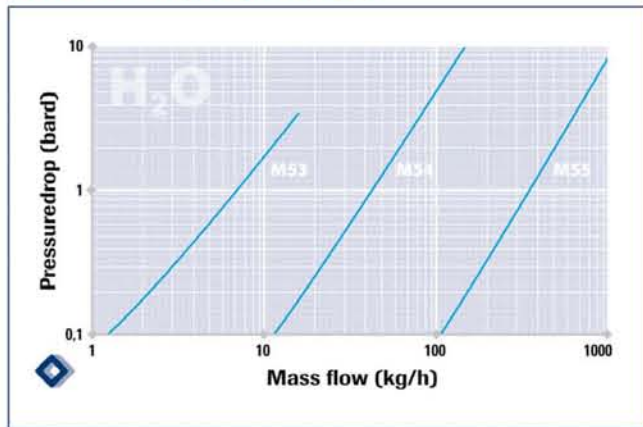

M50C2-Series Mass Flow Controller

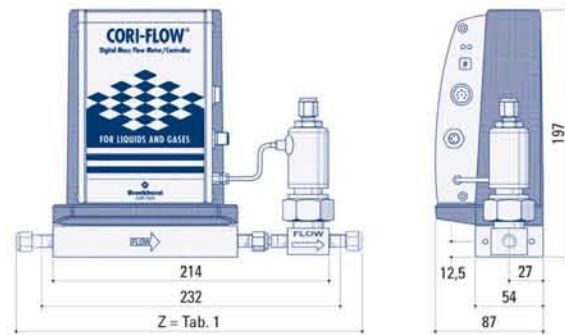

Pressure P₁ vs. mass flow for Air (P₂ = 1 bara)

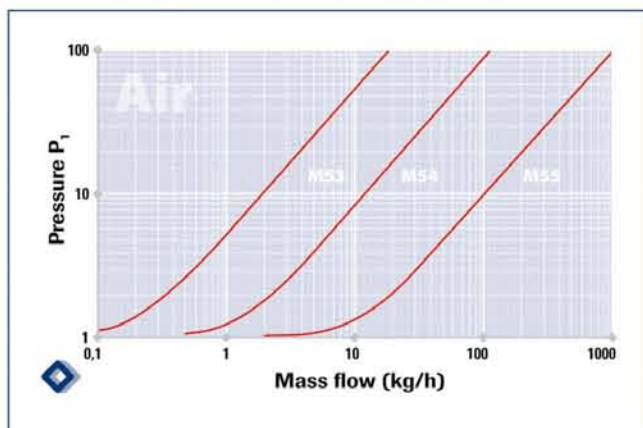

M50C4-Series Mass Flow Controller

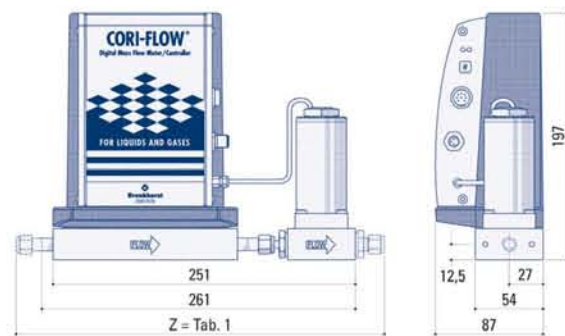

* Capacity based on air flow measurement: capacity shown increases with pressure; max. allowable pressure is 100 bara.

M50C5I-Series Mass Flow Controller

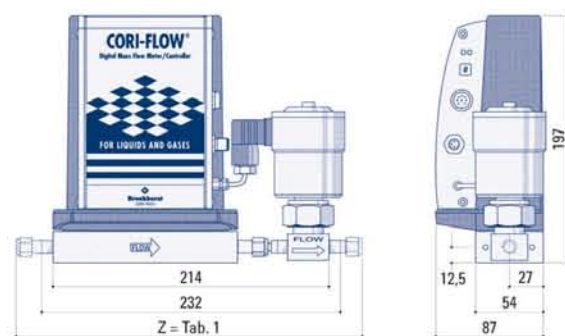

Table 1 (Z-values in mm)

Connections (in/out)	M50	M50C2/ M50C5I	M50C4
1/8" compression type	201	267	-
1/8" face seal male	194	260	-
1/4" compression type	204	270	306
1/4" face seal male	202	267	301
1/4" face seal female	202	267	-
6 mm compression type	204	270	306

Technical specifications and dimensions subject to change without notice.
 Dimensional drawings for other MFCs available on request.

모델 식별 형번(Model number identification)

M5N - AN(I) - A A A - NN - A - A

Mass flow meter

M53	Nominal range	5 kg/h
M54	Nominal range	50 kg/h
M55	Nominal range	500 kg/h

Control valve

C0 (I)	Low Flow control valve (nc) PN100	gas; Kv-max = $6,6 \times 10^{-2}$
C1 (I)	Low Flow control valve (no) PN100	gas; Kv-max = $6,6 \times 10^{-2}$
C2 (I)	Low Flow control valve + purge connection (nc) PN100	liquid; Kv-max = $2,3 \times 10^{-3}$
C3 (I)	Low Flow control valve + purge connection (no) PN100	liquid; Kv-max = $2,3 \times 10^{-3}$
C4 (I)	Medium Flow control valve (nc) PN10	gas or liquid; Kv-max = $3,0 \times 10^{-1}$
CS1	Medium Flow control valve (nc) PN100, IP65	gas or liquid; Kv-max = $6,6 \times 10^{-2}$

add 'I' for IP65 coil on control valve

PC-board

A	with RS232 and analog I/O	(nc)	controller-function
B	with RS232 and analog I/O	(no)	controller-function
D	with RS232 and DeviceNet I/O	(nc)	controller-function
E	with RS232 and DeviceNet I/O	(no)	controller-function
M	with RS232 and Modbus I/O	(nc)	controller-function
N	with RS232 and Modbus I/O	(no)	controller-function
P	with RS232 and Profibus I/O	(nc)	controller-function
Q	with RS232 and Profibus I/O	(no)	controller-function
R	with RS232 and FLOW-BUS I/O	(nc)	controller-function
S	with RS232 and FLOW-BUS I/O	(no)	controller-function

Output

A	0...5V
B	0...10V
F	0...20 mA sourcing
G	4...20 mA sourcing

Supply voltage

D	+ 15...24 Vdc
---	---------------

Connections (in/out)

1	1/8"	OD compression type
2	1/4"	OD compression type
3	6 mm	OD compression type
4	12 mm	OD compression type
5	1/2"	OD compression type
7	1/4"	Face seal female
8	1/4"	Face seal male
9	Other	

Internal seals

0	None (sensors)
V	Viton (valves for gas)
E	EPDM
K	Kalrez-6375

Material

S	Stainless steel
H	Hastelloy-C22



M50C5I series Mass Flow Controllers



CORI-FLOW® Mass Flow Meter with dosing pump and filter

Bronkhorst®
HIGH-TECH

Nijverheidsstraat 1a, NL-7261 AK Ruurlo The Netherlands
T +31(0)573 45 88 00 F +31(0)573 45 88 08
E info@bronkhorst.com

고객우선주의
JAT (주) 제이에이티
Jung-Ang automatic technology

경기도 안산시 단원구 고잔동 717-1 프리미어스 빌딩 8동 305호
Tel: 031-483-8660 Fax: 031-483-8664
E-mail: jac@ckcd.co.kr Homepage: ckcd.co.kr

